

PROBLEM/SOLUTION

AES67 is an open public standard that defines the use of technologies to allow the exchange of audio and clocking information between devices that implement a variety of different IP media networking solutions. Intended to increase interoperability between different media networking technologies currently on the market today, AES67 allows the exchange of audio among different technologies and vendors, an application that previously required expensive and complicated protocol conversations and configuration. However, as AES67 defines a limited subset of media networking features, it is best implemented inside of a more complete media networking architecture such as Dante, Ravenna, LiveWire or other technologies that support AES67 interoperability. Due to the different implementations of AES67, and media networking elements that are not included in the AES67 specification (such as discovery methods or connection management), some additional details are needed to properly configure the exchange of audio between these different systems and technologies. Though there are many technologies and implementations of AES67 on the market today, this application note addresses the details of connecting two specific implementation - OMNEO, which uses Audinate's Dante, and Ravenna, which is used by some manufacturers, such as Lawo.

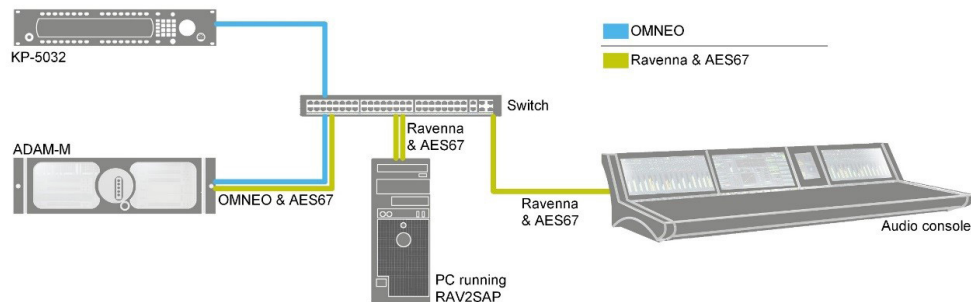

Figure 1. Connecting OMNEO devices to Lawo

TECHNICAL CONSIDERATIONS

When preparing to interface a RTS OMNEO product to a Ravenna product, it is important to consider the following details about how AES67 will work within the installed system.

Discovery - AES67 defines multiple discovery mechanisms that may be implemented. In order to work with OMNEO or other Dante devices, Session Announcement Protocol (SAP) must be used. This enables Dante Controller to see the other AES67 devices natively so the user can configure connections. Though Ravenna implements a unique discovery mechanism, ALC NetworkX provides a free utility called RAV2SAP that is able to convert these native advertisements to SAP so that Dante Controller may see the advertisements to establish connections. This is shown in Figure 1. The PC shown in the figure must always be connected to the system.

Multicast audio only - Currently OMNEO and Dante devices that support AES67 only support the use of multicast AES67 audio streams. The multicast addresses that are used must be in the range of 239.69.0.0-239.69.255.255/16

Connections are not persistent after a system reboot - Because of the mechanisms that are used for connection management, established connections are not retained between system power cycles. Additionally, a computer running the RAV2SAP software must be left online to maintain the discovery advertisements. If a system is power cycled, these connections will need to be manually reestablished.

Fixed 2 ms latency - Although technologies such as OMNEO and Dante support much higher latencies to allow greater distances, AES67 only requires 2 ms latencies. A manufacturer may implement additional options.

Clocking - AES67 requires the use of IEEE 1588 v2 clocking. This poses something of a challenge for the network as OMNEO and Dante also need to support the use of IEEE 1588 v1 to maintain compatibility with non-AES67 Dante equipment. Fortunately, AES67-enabled Dante and OMNEO devices support both IEEE 1588 v1 and v2, although care needs to be taken in the system configuration to ensure proper operation. The most straightforward approach is outlined below, that of using an AES67-enabled Dante/OMNEO device as master for both PTP domains.

1. Enable the device's "Preferred Master" status. In our example, that is the OMI-card of the ADAM-M matrix.
2. Disable "Preferred Master" status for all Dante/OMNEO devices that have AES67 disabled. In our example, that would be the KP-5032 keypanel.
3. Disable "Sync to External" for all devices.
4. Assign a PTP version 2 priority level between 128 and 255 for all non-Dante/non-OMNEO devices.

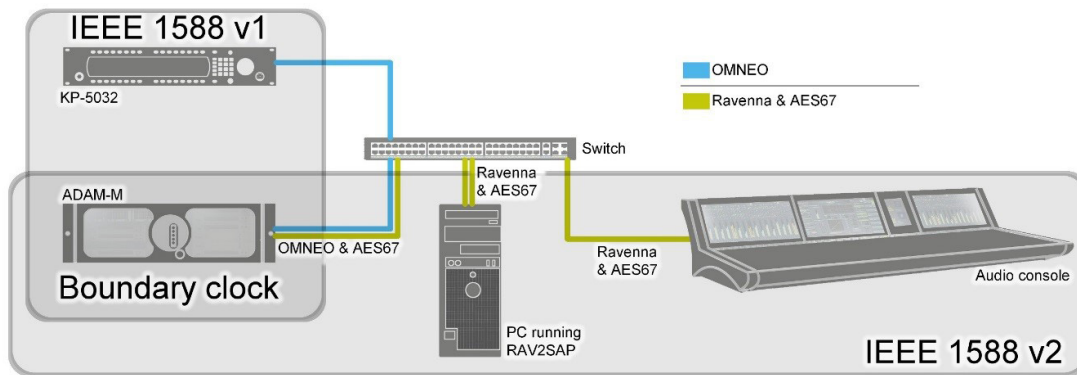

Figure 2. The OMI-card in the ADAM-M bridges the two PTP domains

QoS Settings - Dante and AES67 use different DSCP values for their audio and clocking packets. This can create a problem as priority conflicts may arise when QoS is configured on a managed network. However, these values can be remapped in a couple of different ways. Ravenna supports the remapping of DSCP values so these can be changed to match those needed by Dante. Alternately, these values can be remapped in a managed network switch that supports this feature.

PRACTICAL CONSIDERATIONS

AES67 provides a level of interoperability between IP media networking systems that has never been achieved before without extensive complexity and use of converters, although it does require additional configurations than a standard OMNEO system.

Use AES67 between systems - The primary benefit of AES67 is provided when it is used to connect different systems. However, as architected media networking solutions such as OMNEO offer additional functionality and features, AES67 is generally used to connect different systems as opposed to being the primary transport for all devices.

Consider network design carefully - Planning for the deployment of systems requires careful thought as to how to connect devices and where to use AES67 links. For example, OMNEO supports latencies up to 20 ms and these allow very long distances between devices. In a situation such as this, AES67 should be used on one side of the link or the other and OMNEO should be used for the long-haul connection.

Consult the manufacturer - AES67 can be implemented in different ways by different manufacturers. Be sure to consult the manufacturer for specific details on their implementation to ensure that elements related to discovery, clocking, QoS, audio formats, and other details will meet your needs.